

EWS .Special Solutions

The optimum solution for every application!

Module milling, slotting, polygonal hole drilling, tapping,
high-speed micro-machining and internal drilling



DOWNLOAD
PDF



www.ews-tools.de

EWS
Tool Technologies



EWS.Slot

Grooving, internal and external gears manufactured completely and position-orientated

Grooving in a new dimension.

Function

- The newly developed EWS.Slot grooving unit converts the rotational movement of the turret drive into a translatory movement with an integrated lift-off function on the return stroke.
- The economical production of internal and external profiles, such as keyways or splines, takes on a new dimension.
- Slotting units can be operated at up to 1500 rpm.



Possible use		Versions	
		Standard	Long
	Stroke length	34	53
	Max. Slot width	10 mm	10 mm
	Effective length	32 mm	51 mm
	Required path for infeed and lifting movement	1 mm	1,5 mm
There must be an undercut at the end of processing!			
Area of application: Small and medium series			

Processing examples



Processing:

- From both sides
- Inner and outer diameter
- Turning
- Cross drilling
- Grooving
- Tooting

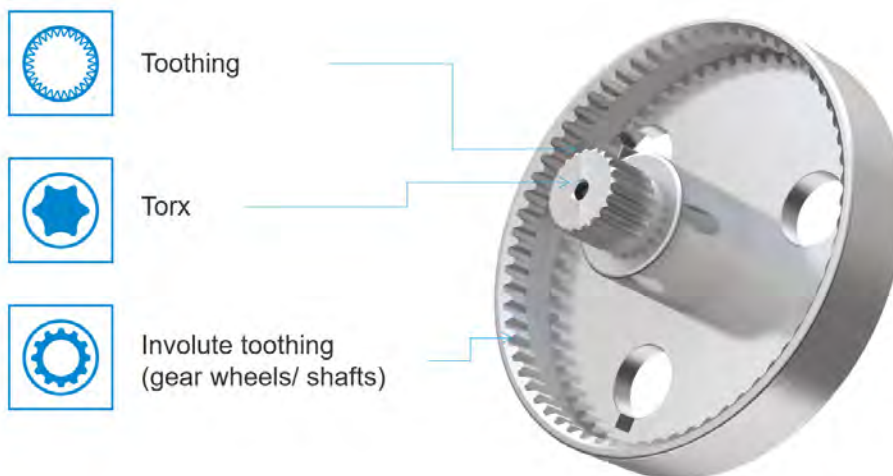
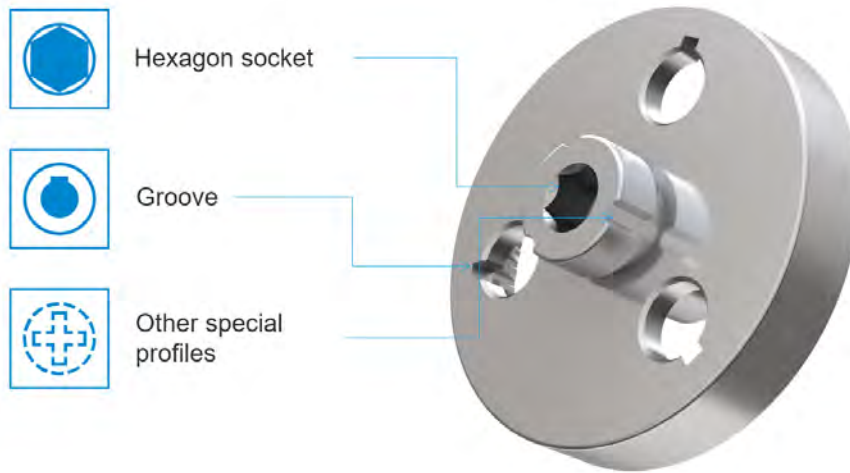

Product video



EWS. Gear hobber

Gear milling on CNC lathes without B-axis

Gear milling on CNC lathes without B-axis

Function

- The milling head can be continuously rotated 360 degrees around the shank axis
- Can be used without a cost-intensive B-axis
- This means that all necessary work steps can be carried out during gear milling without reclamping

Technical details

- Gearings up to module 3 are possible
- Milling arbors available in different diameters ($\varnothing 8$ - $\varnothing 32$) machine-specific
- Achievable quality: 9-12 (depending on machine, material and cutting tool)
- Available for disc and star turrets

Prerequisite

- Cycle for gear hobbing must be enabled (coupling tool drive with C-axis)



Product video

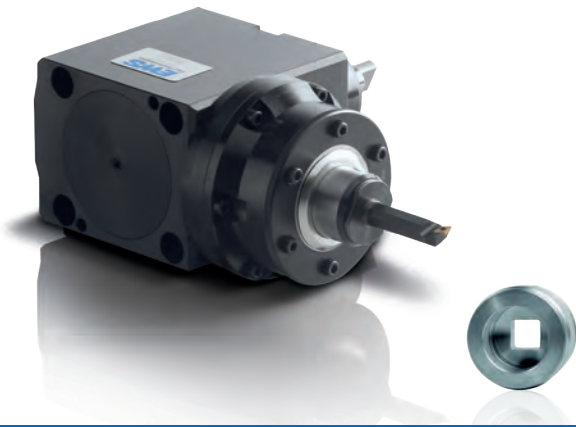

EWS Multiform

4-, 6- or 8-edge, polygon or free-form shapes with EWS-Multiform on CNC turning/milling centres

Create any desired shape centrally or eccentrically.

Function

- The profile to be machined is generated using correspondingly designed cam discs. Standard and special designs are possible.
- The drive is provided by the turret station for driven tools.
- Attention: Restriction for turrets whose driven tools are operated permanently, as the speed is limited to 1000 rpm for size 1 (500 rpm* for size 2).

Application area

- Size 1
Square 4 - Square 14,
Hexagon 4 - Hexagon 21,
Octagonal on request
- Size 2*
Square 4 - Square 22,
Hexagon 4 - Hexagon 36,
Other contours on request



Prerequisite

- Turret for driven tools
- Machine VDI20 - VDI60 and BMT55 - BMT85



*Special solution



EWS . SpinJet

High-speed machining up to 55,000 rpm with real-time speed measurement

High-speed machining up to 55,000 rpm with real-time speed measurement

Function

- Coolant-driven high-speed spindle utilises the existing coolant supply of the machine spindle
- Saves up to 70% of the machining time (20,000 to 55,000 rpm)
- High-speed machining
- Less tool and machine wear

Machine requirements

- 20 - 40 bar Coolant pressure
- 10 - 20 l/min Volume flow

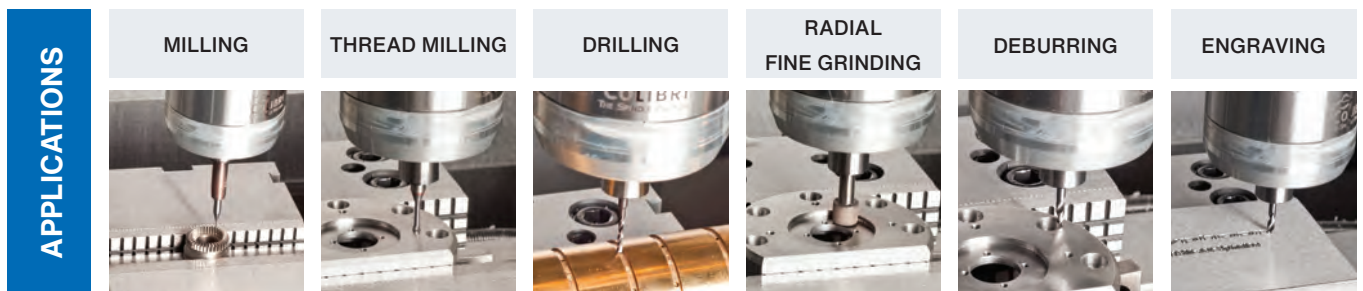



EWS . TAPMATIC

High-speed thread cutting with reversing kinematics

The units are available for threads from M3-M12.

Features

- Automatic reversal of direction of rotation
- Length compensation on tension
- Constant cutting speed

Advantages

- Reduction in processing time of up to 50%
- Increase in production capacity
- Increase the service life of the threading tool by a factor of 3
- Machine protection (avoidance of spindle changeover)
- Around 75% power savings by eliminating braking and starting up the machine

Availability

■ Radial tapping attachments RSR

Cutting range	M4.5-M12	
Speed 1/min	2500	$i = 1.5:1$

■ Axial tapping attachments ASR

Cutting range	M4.5-M12	
Speed 1/min	2500	$i = 1:1$



Internal drilling heads

Masterful precision in the
in the smallest of spaces.

Internal drilling heads enable the machining of hard-to-reach internal areas with high precision, even with small tool diameters and large plunge depths.

Function

- Machining of areas that are difficult to access, e.g. inside diameters, is possible
- Various gear ratios can be realised for higher speeds with small tool diameters
- Can be used for star and disc turrets
- Feasible from an internal diameter of 45 mm
- Large immersion depths possible, previously realised up to 300 mm

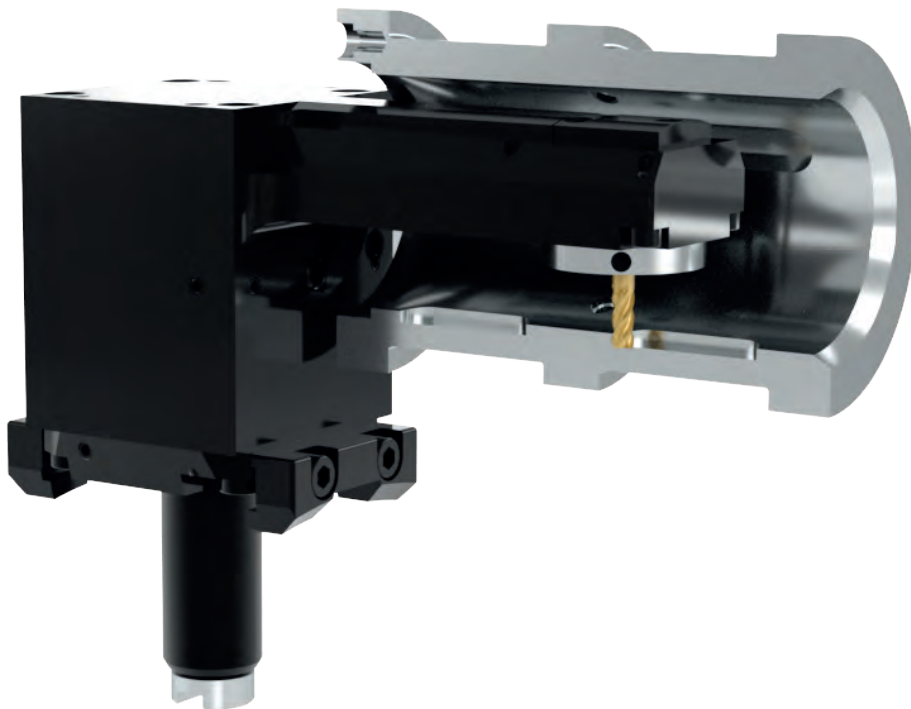
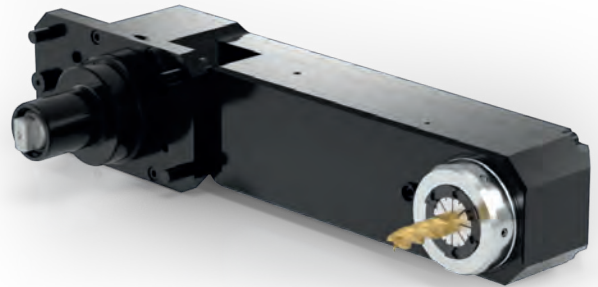

EWS Group

Tooling Systems and Turrets

EWS USA

EWS USA

13931 Sunfish Lake Blvd NW
Ramsey · MN 55303 USA
Telefon +1-763-576-6910
E-Mail support@ews-tools.com
www.ews-tools.com

EWS

Tool Technologies

EWS Weigle GmbH & Co. KG

Maybachstraße 1 · D-73066 Uhingen
Telefon +49(0)7161-93040-100
E-Mail info@ews-tools.de
www.ews-tools.de

EWS Türkiye

EWS Tutucu Sistemleri ve Taretleri Anonim Şirket

Aydınlı mah. Melodi No.2/19 Sk. Bİlmo
San.Sit. 18-19 · 34956 Tuzla / İstanbul
Turkey
Telefon +90-216-593-22-44
E-Mail mehmet@ewstools.com
www.ews-tools.de

EWS China

EWS Tool Holder Technologies (Taicang Co. Ltd)

Beijing East Road No. 88
215400 Taicang · Jiangsu
P. R. China
Telefon +86-512-3306-2600
E-Mail sales.cn@ews-tools.de
www.ews-tools.cn

EWS Korea

EWS Korea Co. Ltd.

80-101 · Golden root-ro
Juchon-myeon · Gimhae-si
Gyeongsangnam-do · Korea
Telefon +82-55-267-8085
E-Mail info@ewskorea.co.kr
www.ewskorea.co.kr